



**INTERCONNECTION
FACILITIES STUDY
REPORT**

GEN-2018-049

Published November 2023

By SPP Generator Interconnections Dept.

REVISION HISTORY

DATE OR VERSION NUMBER	AUTHOR	CHANGE DESCRIPTION
November 10, 2023	SPP	Initial draft report issued.
November 29, 2023	SPP	Final report issued.
October 2, 2024	SPP	Table 4 updated to reflect Restudy results.

CONTENTS

Revision History	i
Summary	1
Introduction	1
Phase(s) of Interconnection Service	1
Compensation for Amounts Advanced for Network Upgrade(s).....	1
Interconnection Customer Interconnection Facilities	2
Transmission Owner Interconnection Facilities and Non-Shared Network Upgrade(s)	3
Shared Network Upgrade(s)	4
Contingent Network Upgrade(s).....	5
Affected System Upgrade(s)	6
Conclusion.....	7
Appendices	8
A: Transmission Owner’s Interconnection Facilities Study Report and Network Upgrades Report(s).....	9

SUMMARY

INTRODUCTION

This Interconnection Facilities Study (IFS) for Interconnection Request GEN-2018-049 is for a 120 MW generating facility located in Sumner, KS. The Interconnection Request was studied in the DISIS-2018-001 Impact Study for ER. The Interconnection Customer's requested in-service date is December 15, 2026.

The interconnecting Transmission Owner, ITC Great Plains (ITCGP), performed a detailed IFS at the request of SPP. The full report is included in Appendix A. SPP has determined that full Interconnection Service will be available after the assigned Transmission Owner Interconnection Facilities (TOIF), Non-Shared Network Upgrades, Shared Network Upgrades, Contingent Network Upgrades, and Affected System Upgrades that are required for full interconnection service are completed.

The primary objective of the IFS is to identify necessary Transmission Owner Interconnection Facilities, Network Upgrades, other direct assigned upgrades, cost estimates, and associated upgrade lead times needed to grant the requested Interconnection Service.

PHASE(S) OF INTERCONNECTION SERVICE

It is not expected that Interconnection Service will occur in phases. However, full Interconnection Service will not be available until all Interconnection Facilities and Network Upgrade(s) can be placed in service.

COMPENSATION FOR AMOUNTS ADVANCED FOR NETWORK UPGRADE(S)

FERC Order ER20-1687-000 eliminated the use of Attachment Z2 revenue crediting as an option for compensation. The Incremental Long Term Congestion Right (ILTCR) process will be the sole process to compensate upgrade sponsors as of July 1st, 2020.

INTERCONNECTION CUSTOMER INTERCONNECTION FACILITIES

The Generating Facility is proposed to consist of Thirty-two (32) 3.75 MW Electronics FS4200M Inverters for a total generating nameplate capacity of 120 MW.

The Interconnection Customer's Interconnection Facilities to be designed, procured, constructed, installed, maintained, and owned by the Interconnection Customer at its sole expense include:

- 34.5 kV underground cable collection circuits;
- 34.5 kV to 345 kV transformation substation with associated 34.5 kV and 345 kV switchgear;
- One 345/34.5 kV 87.6/116.8/146 MVA (ONAN/ONAF/ONAF) step-up transformer to be owned and maintained by the Interconnection Customer at the Interconnection Customer's substation;
- An Approximately 0.3 miles overhead kV line to connect the Interconnection Customer's substation to the Point of Interconnection ("POI") at the 345 kV bus at existing Transmission Owner substation ("Thistle 345kV Substation") that is owned and maintained by Transmission Owner;
- All transmission facilities required to connect the Interconnection Customer's substation to the POI;
- Equipment at the Interconnection Customer's substation necessary to maintain a composite power delivery at continuous rated power output at the high-side of the generator substation at a power factor within the range of 95% lagging and 95% leading in accordance with Federal Energy Regulatory Commission (FERC) Order 827. The Interconnection Customer may use inverter manufacturing options for providing reactive power under no/reduced generation conditions. The Interconnection Customer will be required to provide documentation and design specifications demonstrating how the requirements are met; and,
- All necessary relay, protection, control and communication systems required to protect Interconnection Customer's Interconnection Facilities and Generating Facilities and coordinate with Transmission Owner's relay, protection, control and communication systems.

TRANSMISSION OWNER INTERCONNECTION FACILITIES AND NON-SHARED NETWORK UPGRADE(S)

To facilitate interconnection, the interconnecting Transmission Owner will perform work as shown below necessary for the acceptance of the Interconnection Customer’s Interconnection Facilities.

Table 1 and **Table 2** list the Interconnection Customer’s estimated cost responsibility for Transmission Owner Interconnection Facilities (TOIF) and Non-Shared Network Upgrade(s) and provides an estimated lead time for completion of construction. The estimated lead time begins when the Generator Interconnection Agreement has been fully executed.

Table 1: Transmission Owner Interconnection Facilities (TOIF)

Transmission Owner Interconnection Facilities (TOIF)	Total Cost Estimate (\$)	Allocated Percent (%)	Allocated Cost Estimate (\$)
<u>Transmission Owner's Thistle 345kV Substation GEN-2018-049 Interconnection (TOIF) (ITCGP) (UID156246): Facilitate the interconnection of GEN-2018-049 Estimated Lead Time: 36 Months</u>	\$1,207,987	100.00%	\$1,207,987
Total	\$1,207,987		\$1,207,987

Table 2: Non-Shared Network Upgrade(s)

Non-Shared Network Upgrades Description	ILTCR	Total Cost Estimate (\$)	Allocated Percent (%)	Allocated Cost Estimate (\$)
<u>Transmission Owner's Thistle 345kV Substation Interconnection Expansion (DISIS-2018-001) (UID156247): Facilitate the interconnection of GEN-2018-049 Estimated Lead Time: 36 Months</u>	Eligible	\$3,473,696	100.00%	\$3,473,696
Total		\$3,473,696		\$3,473,696

SHARED NETWORK UPGRADE(S)

The Interconnection Customer’s share of costs for Shared Network Upgrades is estimated in **Table 3** below.

Table 3: Interconnection Customer Shared Network Upgrade(s)

Shared Network Upgrades Description	ILTCR	Total Cost Estimate (\$)	Allocated Percent (%)	Allocated Cost Estimate (\$)
<u>N/A</u>				
Total		\$ 0		\$ 0

All studies have been conducted assuming that higher-queued Interconnection Request(s) and the associated Network Upgrade(s) will be placed into service. If higher-queued Interconnection Request(s) withdraw from the queue, suspend or terminate service, the Interconnection Customer’s share of costs may be revised. Restudies, conducted at the customer’s expense, will determine the Interconnection Customer’s revised allocation of Shared Network Upgrades.

CONTINGENT NETWORK UPGRADE(S)

Certain Contingent Network Upgrades are **currently not the cost responsibility** of the Interconnection Customer but will be required for full Interconnection Service.

Table 4: Interconnection Customer Contingent Network Upgrade(s)

Contingent Network Upgrade(s) Description	Current Cost Assignment	Estimated In-Service Date
Line - Wolf Creek - Blackberry 345 kV: Build a new 345kV line from Wolf Creek to Blackberry with a summer emergency rating of 1792 MVA. Install terminal equipment at Wolf Creek to support 345kV line from Wolf Creek to Blackberry rated at 1792 MVA (NTC - 210592/210626)	\$0	7/15/2025

Depending upon the status of higher- or equally-queued customers, the Interconnection Request’s in-service date is at risk of being delayed or Interconnection Service is at risk of being reduced until the in-service date of these Contingent Network Upgrades.

AFFECTED SYSTEM UPGRADE(S)

To facilitate interconnection, the Affected System Transmission Owner will be required to perform the facilities study work as shown below necessary for the acceptance of the Interconnection Customer’s Interconnection Facilities. **Table 5** displays the current impact study costs provided by either MISO or AECI as part of the Affected System Impact review. The Affected System facilities study could provide revised costs and will provide each Interconnection Customer’s allocation responsibilities for the upgrades.

Table 5: Interconnection Customer Affected System Upgrade(s)

Affected System Upgrades Description	Total Cost Estimate (\$)	Allocated Percent (%)	Allocated Cost Estimate (\$)
<u>N/A</u>			
Total	\$ 0		\$ 0

CONCLUSION

After all Interconnection Facilities and Network Upgrades have been placed into service, Interconnection Service for 120 MW can be granted. Full Interconnection Service will be delayed until the TOIF, Non-Shared NU, Shared NU, Contingent NU, Affected System Upgrades that are required for full interconnection service are completed. The Interconnection Customer’s estimated cost responsibility for full interconnection service is summarized in the table below.

Table 6: Cost Summary

Description	Allocated Cost Estimate
Transmission Owner Interconnection Facilities Upgrade(s)	\$1,207,987
Non-Shared Network Upgrade(s)	\$3,473,696
Shared Network Upgrade(s)	\$ 0
Affected System Upgrade(s)	\$ 0
Total	\$4,681,683

Use the following link for Quarterly Updates on upgrades from this report: <https://spp.org/spp-documents-filings/?id=18641>

A draft Generator Interconnection Agreement will be provided to the Interconnection Customer consistent with the final results of this IFS report. The Transmission Owner and Interconnection Customer will have 60 days to negotiate the terms of the GIA consistent with the SPP Open Access Transmission Tariff (OATT).

APPENDICES

**A: TRANSMISSION OWNER'S INTERCONNECTION FACILITIES STUDY
REPORT AND NETWORK UPGRADES REPORT(S)**

See next page for the Transmission Owner's Interconnection Facilities Study Report and Network Upgrades Report(s).

**Generation Interconnection Facilities Study Report
For 2018-049 (Pixley II) Solar Generating Facility
In Barber County, Kansas.
October 11 , 2023**



Table of Contents

1.0 Overview.....3

 1.1 Facility Study Summary3

2.0 Voltage Guidelines.....4

3.0 Network Upgrades4

 3.1 ITCGP GEN 2018-049 Interconnection at Thistle Substation4

4.0 Transmission Owner Interconnection Facilities6

5.0 GEN 2018-049 Interconnection Facilities.....8

6.0 Right of Way Requirements.....8

1.0 Overview

ITC Great Plains (“ITCGP”) has performed a facility study at the request of Southwest Power Pool (“SPP”) for Generation Interconnection request GEN 2018-049 under the SPP Open Access Transmission Tariff. The subject request entails interconnecting a 120MW solar powered generation facility in Barber, Kansas. The project will interconnect at Thistle Substation. It is scheduled for completion by December 15, 2026. this date will be revised further into the process.

The ITCGP scope of this Facility Study is to provide a cost estimate for the Customer’s interconnection facilities. This study does not directly address any of the Network Upgrades that may be identified in the DISIS 2018-001, the facilities that are being constructed by the interconnection customer, or any potential sub-transmission facilities (if any) that may be required.

1.1 Facility Study Summary

ITCGP estimates the total project cost of the customer’s interconnection facilities will be **\$4,681,683**(+/- 20 % accuracy) including applicable company overheads in 2023 dollars. It includes **\$3,473,696** for Network Upgrades and **\$1,207,987** Transmission Owner Interconnection Facilities. It is further estimated that the required legal/real estate acquisition and construction activities will require approximately 24 months after the GIA is executed. The attached report contains additional details regarding the estimate as well as results of short circuit studies, review of reactive compensation, and information on Interconnection & Operating requirements.

ITCGP intends to self-fund the network upgrades for this project and will require a Facility Service Agreement to be negotiated in parallel with the GIA for this project.

The GEN 2018-049 interconnection facilities will require Network Upgrades on the ITCGP system to connect the new generation. Network Upgrades consist of the following:

- Add 2-breakers at Thistle Substation for GEN 2018-049 POI .
- Expansion of Thistle Substation.

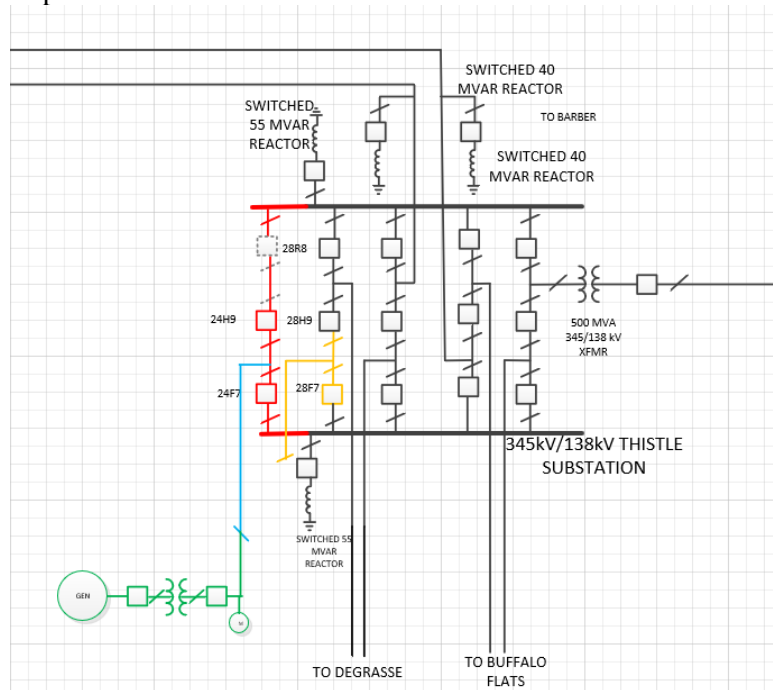

In addition to the identified Network Upgrades, there are specific Interconnection Facilities which ITCGP will construct, own, operate, and maintain. These facilities include the new line entrance structure and 345kV disconnect switch on the end of the radial line at the ITCGP switching station as well as any ITCGP relaying and control equipment required for the protection of the developer’s radial line.

The Interconnection Customer is responsible for constructing all sole-use facilities such as the solar farm collector station and the radial 345kV line from the collector station to the new ITCGP switching station. While this report does define Interconnection Customer owned Interconnection Facilities in enough detail to explain basic requirements, it does not define or contain all of the detailed requirements. Additional metering, communications, and operational requirements may be identified as the Interconnection and Operating Agreements are developed and further communications between the Transmission Owner and Interconnection Customer take place. The Interconnection Customer’s low voltage system is not defined in this report.

2.0 Voltage Guidelines:

Reactive power, voltage regulation and operating requirements will be as per Transmission Operator (TOP) and Transmission Provider directives. Interconnection Customer will operate the Generating Facility to a voltage schedule of 350 kV (1.014 pu) with a bandwidth of +/- 6 kV (0.017 pu) at the Point of Interconnection (POI) utilizing the Generating Facility’s required power factor design capability as indicated in SPP DISIS 2018-001. As per SPP DISIS 2018-001, the Interconnection Customer’s required power factor capability is 0.95 lagging to 0.95 leading (at the POI).

For further clarification, the Interconnection Customer may meet the +/- 0.95 power factor requirement by utilizing reactive capability from the solar generators or by adding external reactive compensation. Note that any reactive compensation installed by the Interconnection Customer shall not cause voltage distortion in accordance with Article 9.7.6 Power Quality of the Generation Interconnection Agreement.

The Interconnection Customer will regulate the Generating Facility’s voltage to the specified voltage set point within the defined bandwidth stated above using an automatic voltage controller utilizing the inherent reactive power capability in the solar farm and if applicable external reactive compensation.

The above voltage schedule is subject to change. If the need for a change is identified, it will be done within the limits of the GIA provisions stated in Section 9.6 and the Generating Facility’s power factor design criteria as stated above. If a schedule change is needed, appropriate written documentation of the change will be provided to the Interconnection Customer.

The Interconnection Customer is required to have a generator operator available for 24/7 communication with the TOP. The TOP may, at any time request a variance from the schedule in response to system operating/security requirements.

3.0 Network Upgrades

3.1 ITCGP GEN 2018-049 Interconnection at Thistle Substation

3.1.1 Fault Currents

	Three-Phase	Single-Line
GEN 2018-049	13764.04	10237.89

Fault currents shown in Table 1 are within the circuit breaker interrupting capabilities with the addition of 120 MW contributed by GEN 2018-049.

3.1.2 Reactive Compensation:

ITCGP evaluated the impact of the proposed interconnection on the reactive compensation equipment presently planned or in service at the Thistle Substation facilities. ITCGP studies concluded that no additional reactive compensation is required for interconnection of GEN 2018-049 at this time ITCGP may review the need for reactive compensation at a future time during which the size of a reactor would be further refined with additional studies after the GIA is signed.

3.1.3 Other Equipment & Materials:

- Gas Circuit Breakers (GCB): (2) 345 kV, 3000A rated, 63kAIC.
- Disconnect Switch: (4) 345 kV, 3000A rated, 1050 kV BIL.
- CCVTs: (3) 345kV, 3-winding, 1550kV BIL.
- Insulators: (40) 345 kV, 1050 kV BIL station post, porcelain.
- Surge Arresters: (3) 345kV, vertical mount, 209MCOV, polymer.
- Control Cable: Control cables per Transmission Owner standards will be installed in direct buried PVC conduits, above grade LFMC conduits and in pre-cast cable trench. All control cables from the yard will be terminated at the relaying control panels. The control building will have overhead cable trays for necessary cable runs and inter-panel connections.

3.1.4 Relaying, Control, & SCADA:

Panel Requirements

- 1 – RD3024 – Tie Breaker Control (SEL-351S)
- 1 – RD3070 – “A” Line Relaying, Carrier (SEL-421 & UPLC)
- 1 – RD3076 – “B” Line Relaying, Carrier (SEL-311C & UPLC)

3.1.5 Grounding System:

The grounding system will be designed and installed per Transmission Owner’s standards. These standards follow the IEEE 80 standards.

3.1.6 Lightning Shielding Design:

Lightning shielding will be provided per Transmission Owner’s standards. Multiple H-frame structures along with shield wire will be used for lightning protection.

3.1.7 Yard Lighting:

Yard lighting will be installed to be sufficient for visual indication of the disconnect switch positions or egress of personnel, and will not serve as task lighting.

3.1.8 Structures:

The required new outdoor steel structures listed below will be hot-dipped galvanized wide flange structures or tubular steel:

- (7) 345 kV disconnect switch stands
- (6) 345 kV bus support
- (1) H-frame line entrance structures

- (3) 345kV CCVT stands
- (3) 345kV surge arrester stands

3.1.9 Foundations:

Foundations and slabs will be designed and installed in accordance with the owner's standards and specifications. The minimum design depth to firm bearing is contingent upon soil borings at the site.

3.1.10 Scheduling Requirements:

Legal/Real Estate Procurement	9 weeks
Material Procurement / Design	52 weeks
Substation Construction	32 weeks
Closeout Activities	4 weeks

3.1.11 Site Work:

Site grading will be required for the new 345kV switchyard.

3.1.12 Total Cost: **\$3,473,696**

Total Cost Estimate Accuracy: +/- 20%

Note that the cost estimate provided is expressed in 2023 terms and includes applicable company overheads.

4.0 Transmission Owner Interconnection Facilities

4.1 Route Information: N/A

4.2 Right-of-Way Information: N/A

4.3 Permitting: N/A

4.4 Metering & Ownership Demarcation:

The Interconnection Customer or others will provide, own, operate and maintain revenue metering. The specifics of the revenue metering will be defined during the detailed engineering phase of the project. The customer must cooperate with the Transmission Provider and Local Transmission Owner requirements in the metering design. Revenue metering equipment will be required at customer's project substation with loss compensation to the Point of Interchange in the Transmission Owner's substation.

The ownership demarcation will be at first substation steel H-frame within the security fence of the Transmission Owner substation.

The Interconnection Customer will be required to provide enough conductor to terminate on the H-frame and extend down to reach grade level.

4.5 Protection & Control Overview:

- One set of 345kV CCVTs will be installed on the GEN 2018-049 line.
- Two paths of fiber optic cable (OPGW) will be required for line protection. They will be supplied by the Interconnection Customer.
- One 345kV line relaying panel with microprocessor-based relays will be installed.

4.6 Insulation Coordination:
345kV, 1050kV BIL

4.7 Short Circuit Study Results - Bus Fault Levels: See Section 3 above.

4.8 Other Equipment & Materials:

- Disconnect Switch: One (1) 345 kV, 3000A rated, 1050 kV BIL.
- CCVTs: Three (3) 345 kV, 3-winding, 1550kV BIL.
- Surge Arresters: Three (3) 345 kV, vertical mount, 209 kV MCOV, polymer.
- Control Cables: Control cables per Transmission Owner standards will be installed in direct buried PVC conduits, above grade LFMC conduits and in pre-cast cable trench. All control cables from the yard will be terminated at the relaying control panels. The control building will have overhead cable trays for necessary cable runs and inter-panel connections.

4.9 Relaying, Control, & SCADA:

Panel Requirements: One RD3048 Panel – Fiber optic current differential (SEL 311L Relays)

4.10 Grounding System:

The grounding system will be designed and installed per Transmission Owner's standards. These standards follow the IEEE 80 standards.

4.11 Lightning Shielding Design:

The attachment of the OPGW shield wire from the developer's line to the H-frame will provide lightning protection for the Interconnection Facility equipment at GEN 2017-004 interconnection substation.

4.12 Yard Lighting:

Yard lighting will be installed to be sufficient for visual indication of the disconnect switch position or egress of personnel and will not serve as task lighting.

4.13 Structures:

The required new outdoor steel structures listed below will be hot-dipped galvanized wide flange structures or tubular steel:

- One (1) 345 kV disconnect switch stand
- Two (1) H-frame line entrance structures
- Three (1) 345 kV CCVT stands
- Three (1) 345 kV surge arrester stands

4.14 Foundations:

Foundations will be designed and installed in accordance with the owner's standards and specifications. The minimum design depth to firm bearing is contingent upon soil borings at the site.

4.15 Conductors, Shield Wires, & OPGW: N/A

4.16 Insulators: N/A

4.17 Removal of Existing Facilities: N/A

4.18 Site Work: N/A

4.19 Total Cost: **\$1,207,987**

Total Cost Estimate Accuracy: +/- 20%

Total Project cost (Network Upgrades and Interconnection facilities): \$4,681,683

Note that the cost estimate provided is expressed in 2023 terms and includes applicable company overheads and potential tax gross ups

5.0 GEN 2018-049 Interconnection facilities

All facilities within the Interconnection Customer's collector substation and between the Interconnection Customer's substation and ITCGP's GEN 2018-049 interconnection at Thistle substation are not included in this report and are the sole responsibility of the Interconnection Customer. Some of the key facilities are briefly mentioned below. The Point of Interconnection (POI) and the Point of Change of Ownership (PCO) are shown in Figure.

The Interconnection Customer shall construct the 345 kV radial line from the Solar farm collector station to ITCGP's Thistle substation. Installation of OPGW shield wire on the radial line from GEN 2018-049 containing at least 12 single mode fibers will be required for ITCGP relaying and communication purposes.

The customer's step-up transformer between the Solar farm's 34.5 kV collector network and the 345 kV facilities will require a high side breaker capable of interrupting a transformer high side winding fault.

All Interconnection Customer owned 345 kV apparatus as well as the revenue metering equipment located in the Interconnection Customer's substation shall comply with ITCGP standards and will be subject to ITCGP approval. ITCGP will provide the Interconnection Customer with standards during detailed design or upon request. The Interconnection Customer is solely responsible for the SCADA and telecommunications facilities necessary to operate and monitor its facility.

Necessary trip and close signal interlocks will be provided by ITCGP to the Interconnection Customer's generation facility for the safe operation of the system. Interconnection Customer will provide breaker status and current transformer signals to ITCGP for system operation and protection.

Total Project Cost: N/A

Total Cost Estimate Accuracy: N/A

6.0 Right Of Way Requirements

The Interconnection Customer shall obtain easements from the Transmission Owner to work in or drive through the Transmission Owner's transmission line right-of-way. The Transmission Owner and Interconnection Customer will also cooperatively negotiate any easements required for the Interconnection Customer's transmission lines and structures. The Transmission Owner agrees to not unreasonably withhold easements.

For the Network Upgrades and any Transmission Owner Interconnection facilities identified in this report, the Transmission Owner agrees to obtain all necessary easements/right-of-way as required to construct those facilities that will be owned and operated by ITCGP.